

Backbone- / Line Coupler, Line Amplifier

Order no.: 0611 00

System information

This unit is a product of the Instabus-EIB-System and corresponds to the EIBA Guidelines. Detailed technical knowledge acquired in Instabus training courses is a prerequisite for the understanding of the system. The functions of the device are software-dependent.

Detailed information on the software and the functions implemented and the software itself are available from the manufacturer's product data bank.

Planning, installation and commissioning of the device are effected with the help of EIBA-certified software.

For the productdatabase and technical descriptions please refer to the Gira Datenpool CD, order no. 1992 10, or to the internet at www.gira.de offering up-to-date information.



Safety warnings

Attention: Electrical equipment must be installed and fitted only by qualified electricians and in observance of the applicable accident prevention regulations.

Any non-observance of the fitting instructions may cause fire or other hazards.

Function

The coupler connects the data flow between two Instabus EIB lines and guarantees electrical isolation between these two lines.

The exact function of the device is determined by its addressing and by the application chosen for it.

LK line coupler:

Connection of a line with a bus (HL), optionally with or without filter function. Physically, the coupler is assigned to the subordinate line (i. e. line).

BK backbone coupler:

Connection of a bus (HL) with a backbone line (BL), optionally with or without filter function. Physically, the coupler is assigned to the subordinate line (i. e. HL bus).

V amplifier:

Preparation and repetition of telegrams on a line, no filter function.

Subdivision of a line into a maximum of 4 independent line segments => a maximum of 3 line amplifiers per line connected in parallel.

For each line segment, a separate power supply (SV) including a choke (DR) is required.

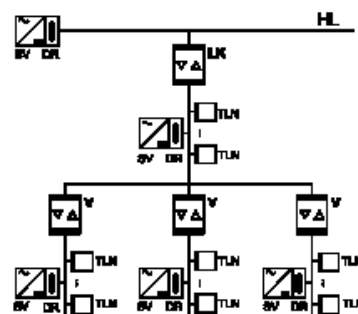
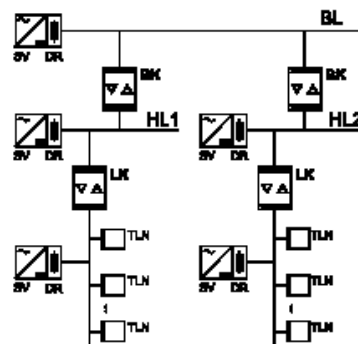

Indicators and Controls (upper illustration):

- ① Programming key.
- ② Programming LED, red.
- ③ Yellow LED (line), to indicate the reception of telegrams on the subordinate line.
- ④ Power-ON LED, green.
- ⑤ Yellow LED (bus), to indicate the reception of telegrams on the higherranking line.

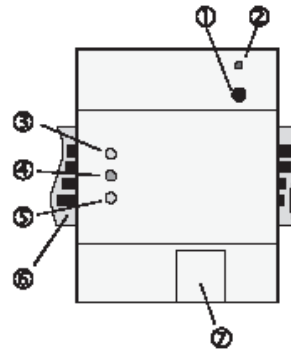

The subordinate line is connected with data bus bar ⑥ by snapping it on, the higher ranking one or the backbone, respectively, through connecting terminal ⑦.

Startup

To assign the physical address press programming key ①. This lights red LED ②. It will go out after the physical address has been taken over. Each line needs a separate power supply.

Topology Schematic Circuit Diagrams of an Instabus EIB System

Middle illustration: Backbone and line coupler application (BK and LK).

Lower illustration: LK line coupler and V amplifier application.

(TLN = bus participant, DR = choke, SV = Instabus power supply)

Technical Data

Supply		Protective system:	IP 20 as per DIN 40 050 (IEC 529)
Instabus EIB:	21 - 32 V DC	Protection class:	III as per IEC 1140
Power Consumption		Mounting width:	70 mm (4 PU (pitch units))
Subordinate line:	200 mW	Battery life	
Higher-ranking line:	15 mW	(without supply voltage):	Approx. 10 years
Instabus EIB Connection		Weight:	206 g
Subordinate line:	Push-contact action onto data bus bar		
Higher-ranking line:	Connecting terminal		
Ambient temperature:	-5 °C to +45 °C		
Storage and transport temp.:	-25 °C to + 70 °C		

Acceptance of guarantee

We accept the guarantee in accordance with the corresponding legal provisions.

Please return the unit postage paid to our central service department giving a brief description of the fault:

Gira
Giersiepen GmbH & Co. KG
Service Center
Dahlienstrasse 12
D-42477 Radevormwald



The CE sign is a free trade sign addressed exclusively to the authorities and does not include any warranty of any properties.

Gira
Giersiepen GmbH & Co. KG
Postfach 1220
D-42461 Radevormwald

Telefon: +49 / 21 95 / 602 - 0
Telefax: +49 / 21 95 / 602 - 339
Internet: www.gira.de